

Chapter 2 - Hydrostatics

CE30460 - Fluid Mechanics

Diogo Bolster



Pressure at a Point

Consider the following setup

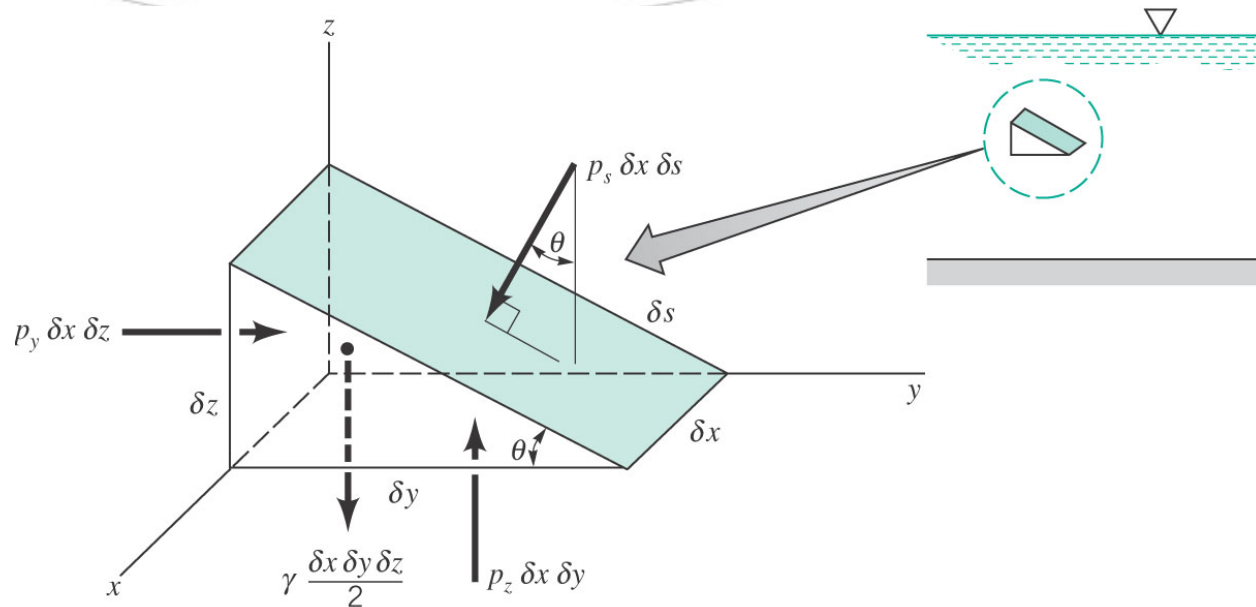

Conclusion: The pressure at a point in a fluid at rest does not depend on direction
As long as no shearing stresses are present (Pascal's Law)

Basic Equation for Pressure Field

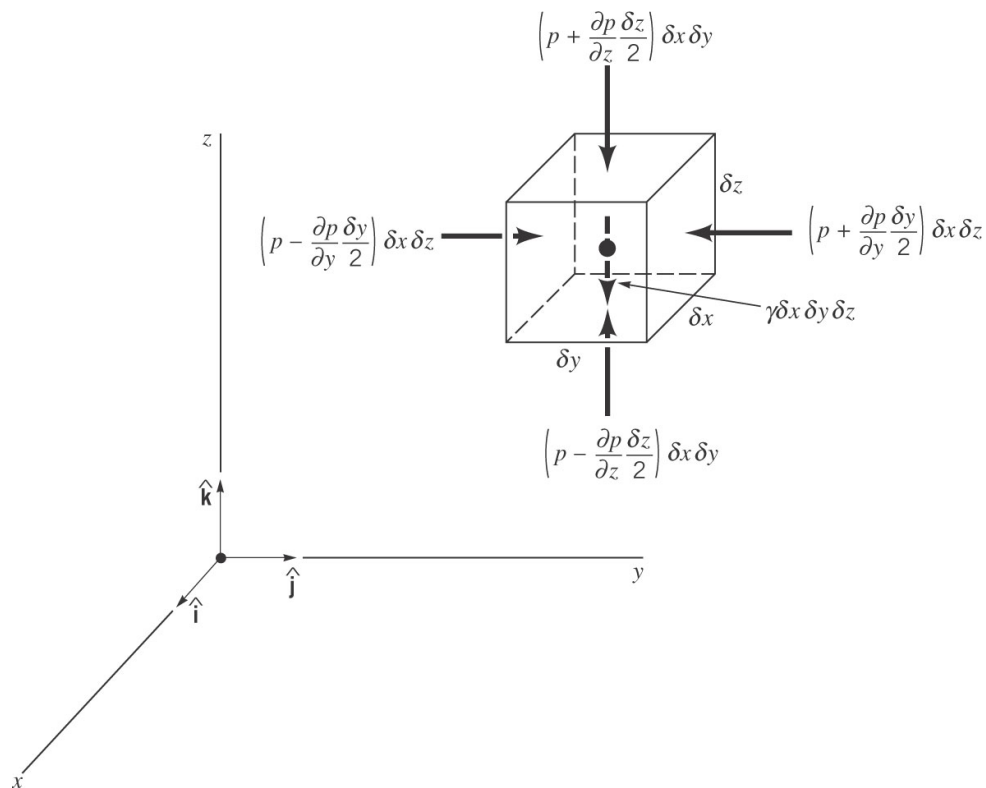

$$-\nabla p - \gamma \hat{k} = \rho \vec{a}$$



Hydrostatic

$$-\nabla p - \gamma \hat{k} = 0$$

Recall $\gamma = \rho g$

Pressure Variation in a Fluid at Rest

$$\frac{\partial p}{\partial x} = 0$$

$$\frac{\partial p}{\partial y} = 0$$

$$\frac{\partial p}{\partial z} = -\gamma$$

Hydrostatic for different Fluids

- ◆ Incompressible \Rightarrow Constant Density
- ◆ Compressible
 - ◆ Isothermal Ideal Gas – $p = \rho RT$
 - ◆ Isentropic $p / \rho^k = \text{constant}$

Sample Problem 1

- ◆ Determine the change in hydrostatic pressure in a giraffe's head as it lowers its head from eating leaves 6m above the ground to getting a drink of water at ground level. Assume that blood has the same density as water
- ◆ Compare this with the pressure of a human heart at 120 mm Hg

Sample Problem 2

- ◆ In a density stratified lake we measure that the density of the lake varies with depth in a manner that can be approximated by the function

$$\rho(z) = 1000 + 1.1 z \quad 0 < z < 100 \text{ m}$$

where $z=0$ is the lake free surface and increases with depth

- ◆ Determine the pressure field

How to measure pressure (Mercury Barometer)

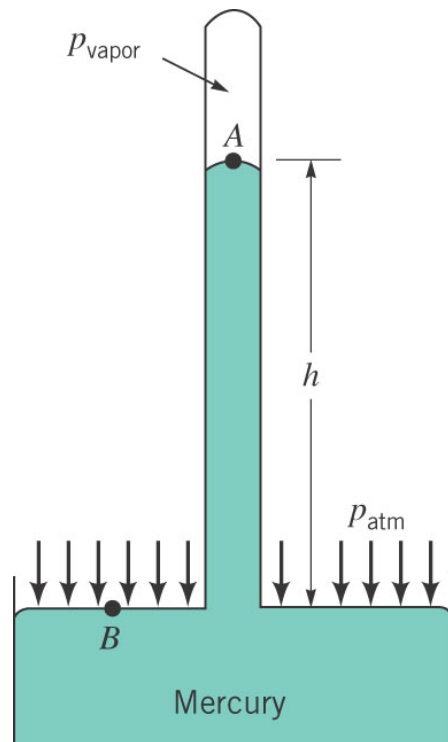

Find a relationship between pressure at A and at B

Often assume $p_{vapor}=0$

How to measure pressure (Piezometer Tube)

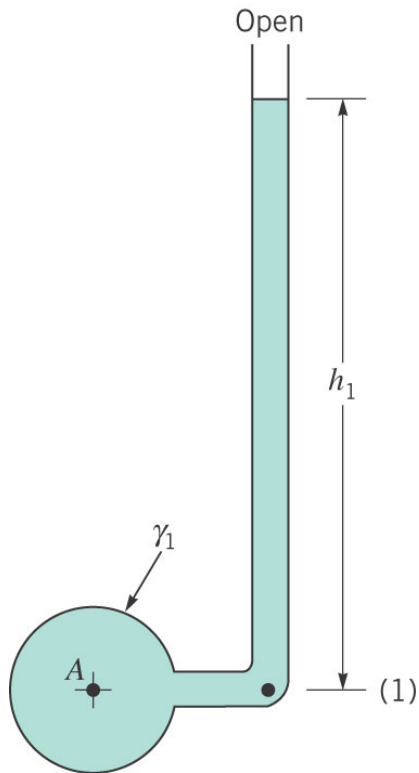

How to measure pressure (U-Tube) Manometer

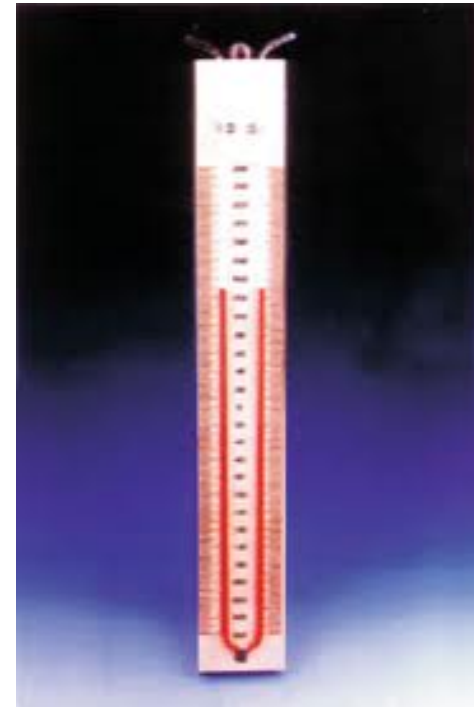
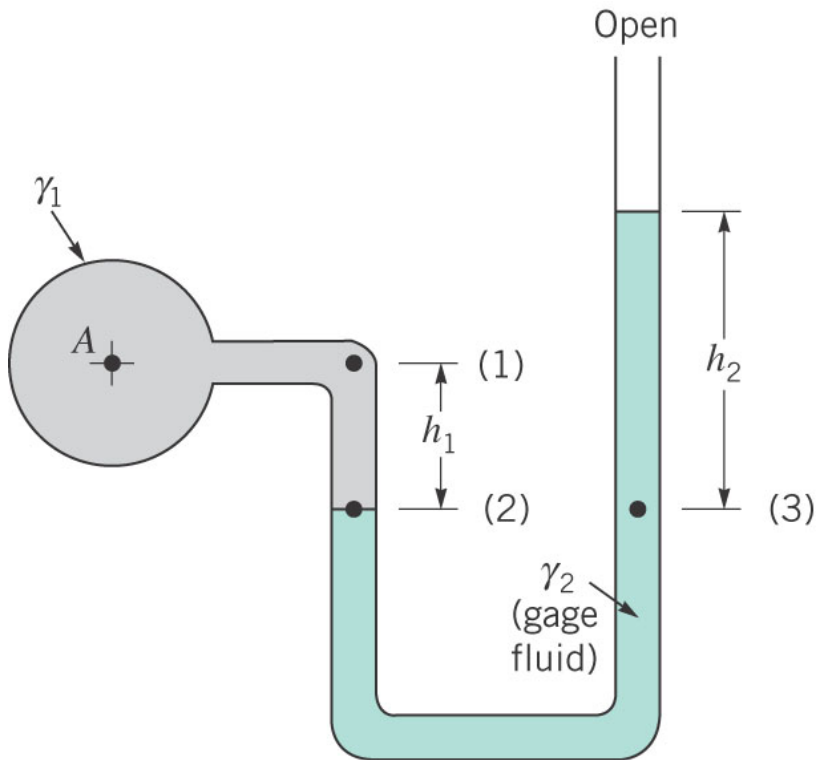

Inclined Manometer

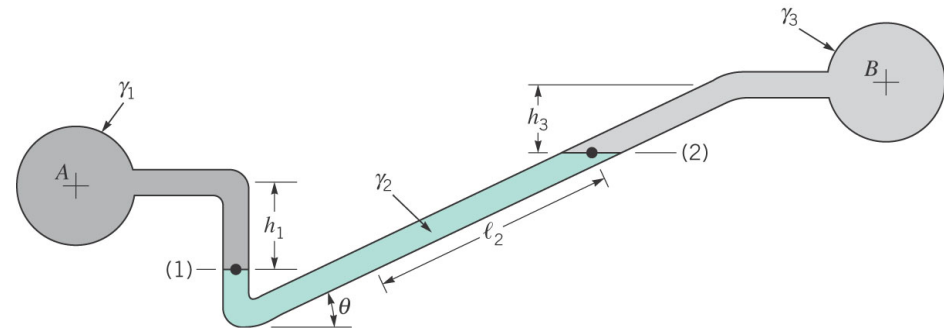

$$p_A + \gamma_1 h_1 - \gamma_2 l_2 \sin \theta - \gamma_3 h_3 = p_B$$

Sensitive to small pressure changes

Other Devices

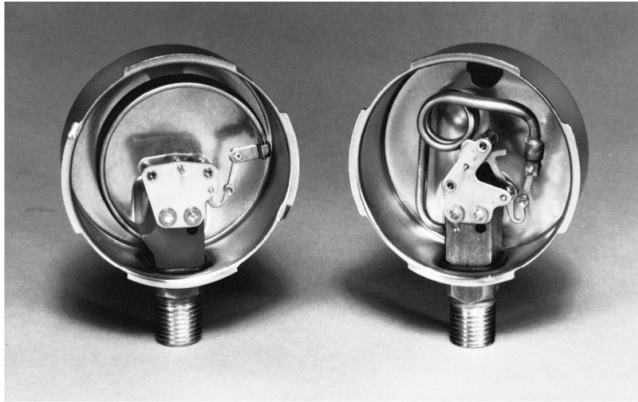

(b)



(a)

Sample Problem

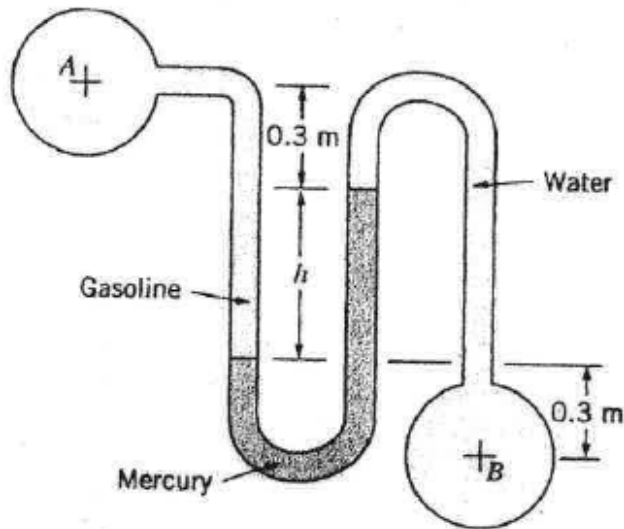

- ◆ Pipe A and B are connected. A contains gasoline ($SG=0.65$) and B water.
- ◆ Determine differential reading h if A has pressure of 20kPA and B has a vacuum of 150mm Hg.

Sample Problem 2

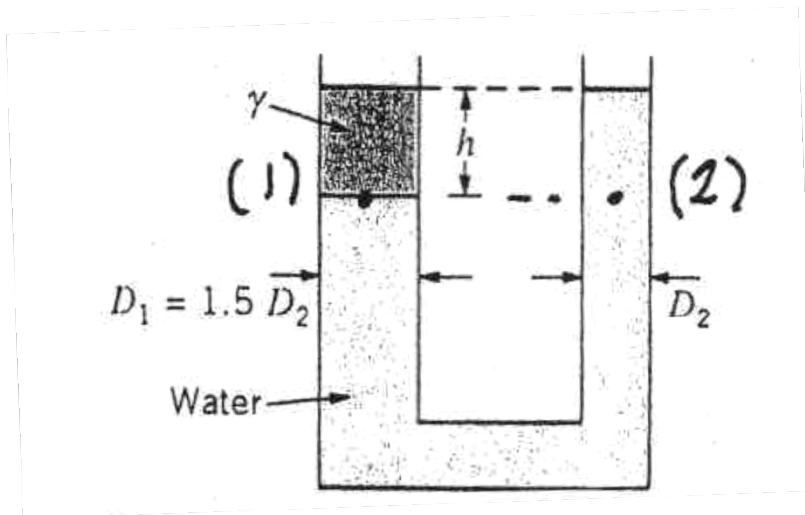

- U-shaped tube initially contains only water. A second liquid of specific weight γ (less than water) is placed on top with no mixing. Can the height h be adjusted so that the left and right levels are the same? Prove it.

Hydrostatic Force on a Plane Surface

$$F = \int_A P dA$$

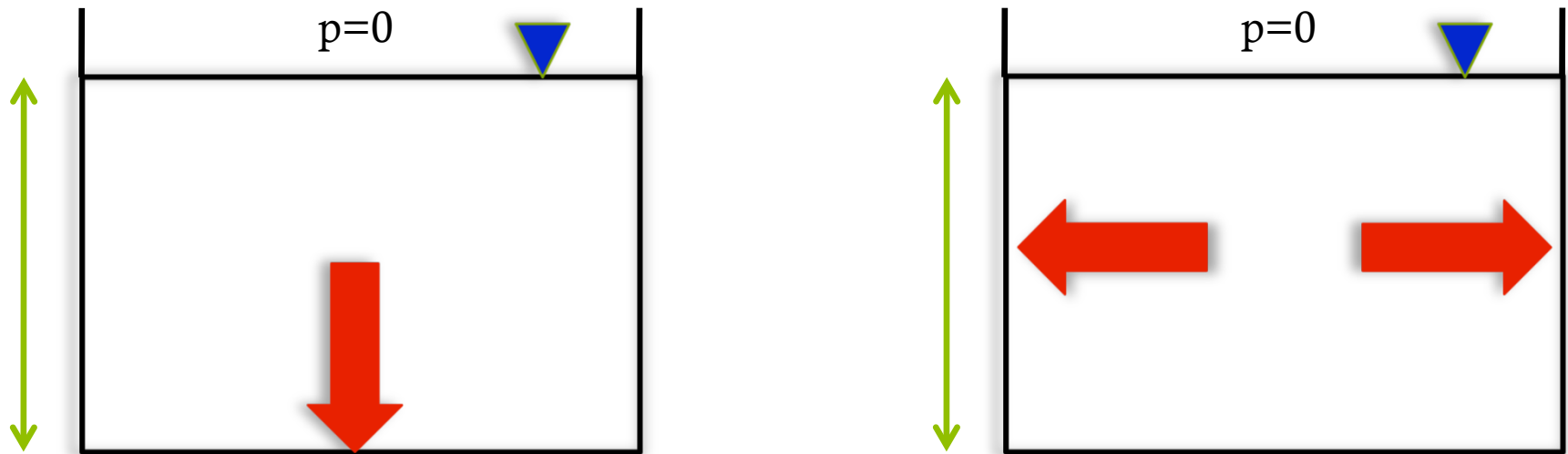

What's the difference in effective force on the bottom vertical surface and horizontal ones?

Here it is....

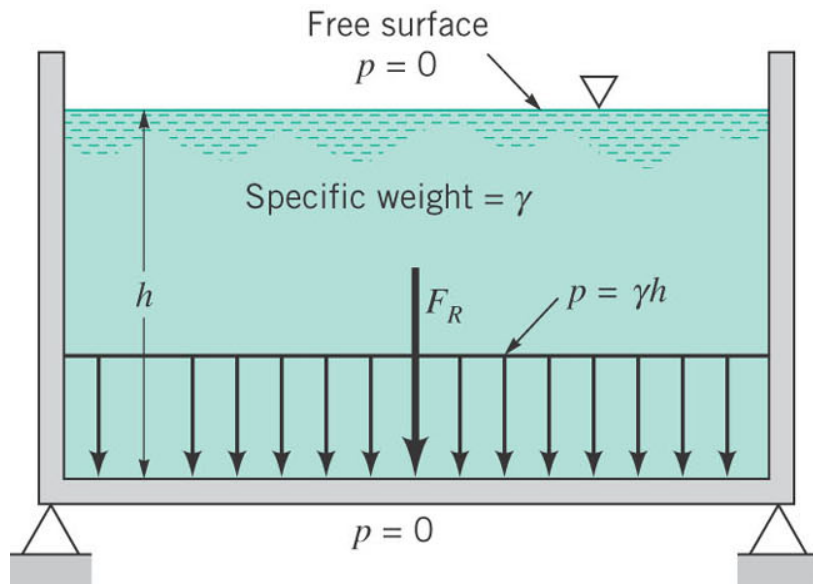

(a) Pressure on tank bottom

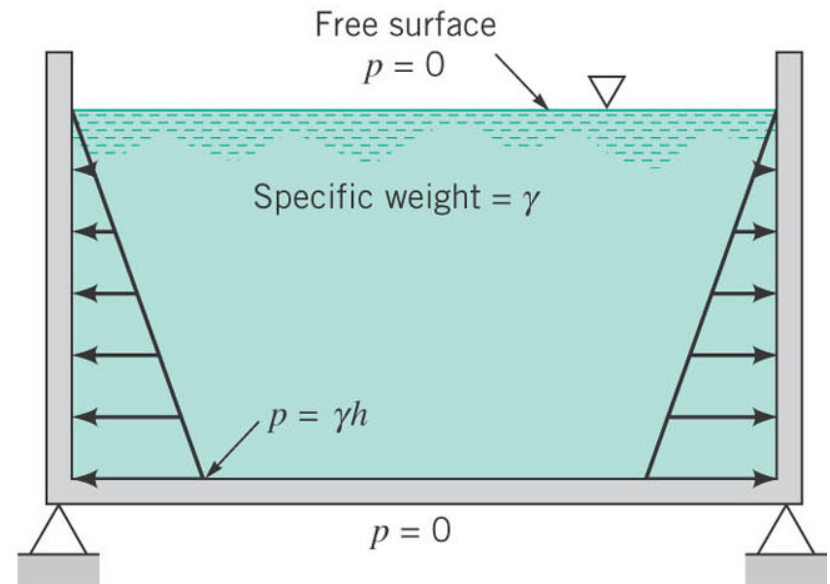

(b) Pressure on tank ends

Uniform vs. varying with depth

Consequences



Pressure on an Inclined Plane

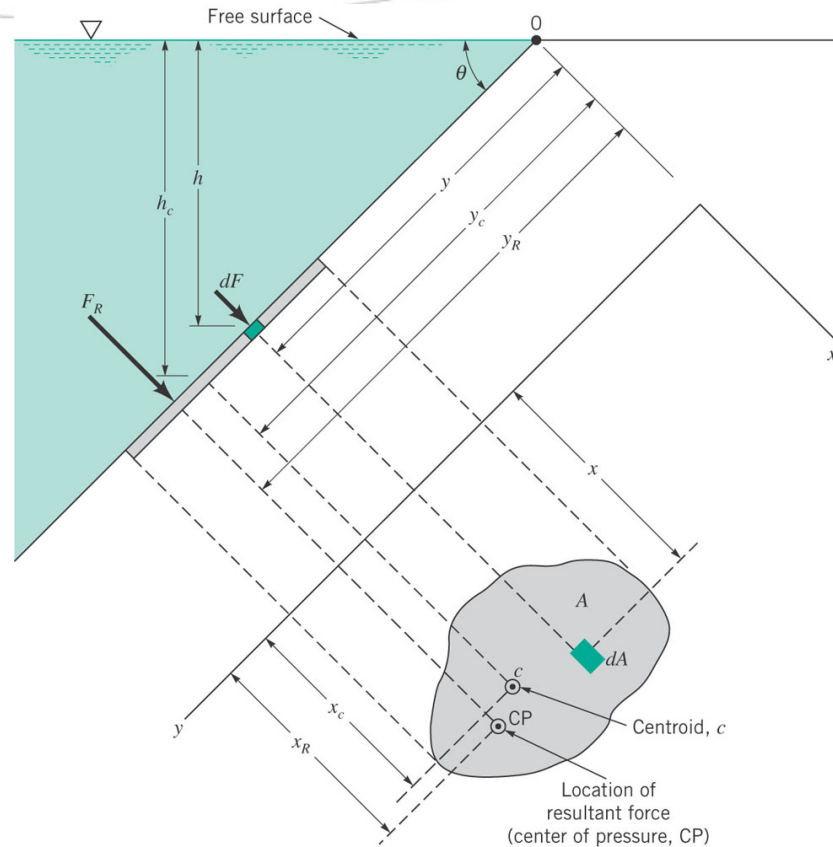

Sample Problem

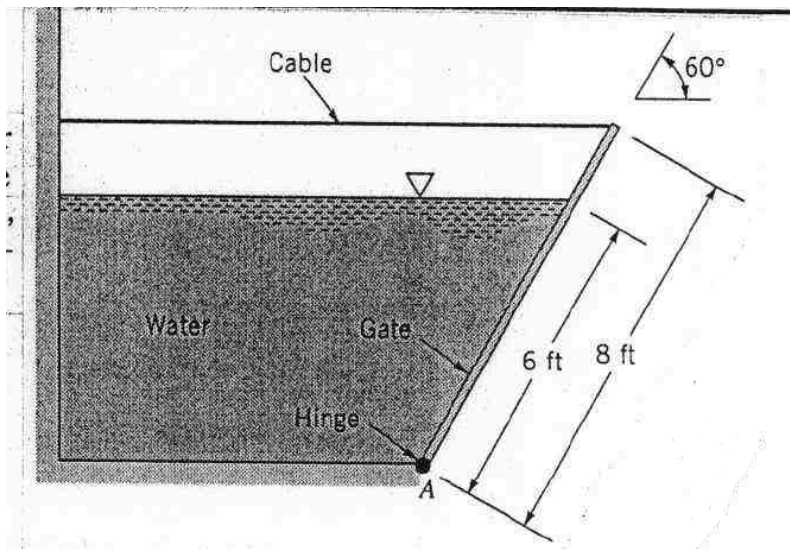

- ◆ A homogeneous, 4 ft wide, 8-ft long rectangular gate weighing 800lb is held in place by a horizontal flexible cable (see figure). Water acts on the gate, hinged at point A. Friction in the hinge is negligible. Determine the tension in the cable.

Concept of Hydraulic Lift

- ◆ Apply a small force
- ◆ Get big force
- ◆ How?

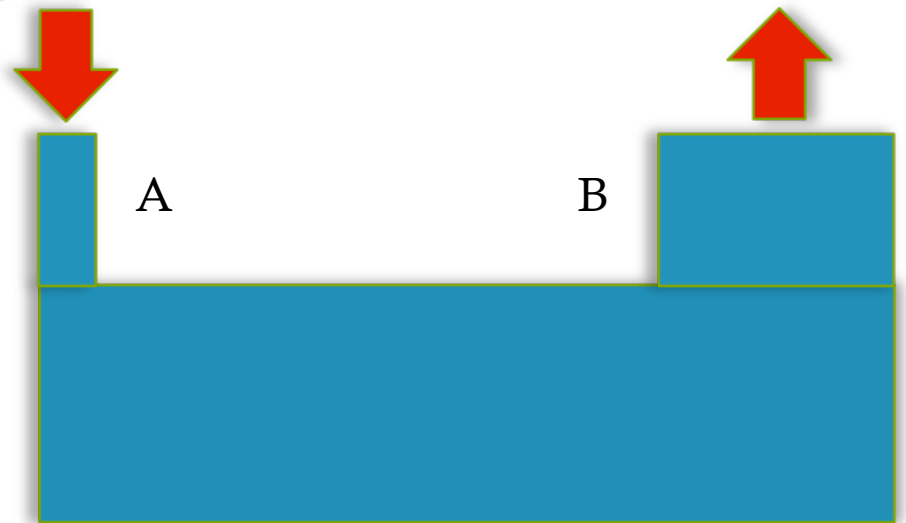

Sample Problem 2

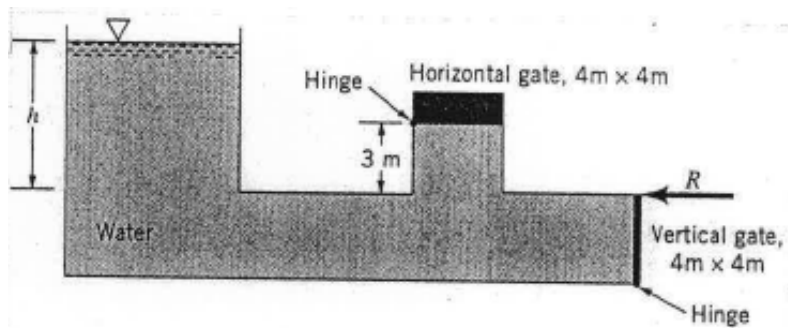

- When water depth $h=5\text{m}$ it is desired that both gates open simultaneously. Determine the weight of the horizontal gate and the horizontal force on the vertical gate needed to keep them closed until this happens. The vertical gate has negligible weight. Friction effects are negligible too.

Pressure Prism

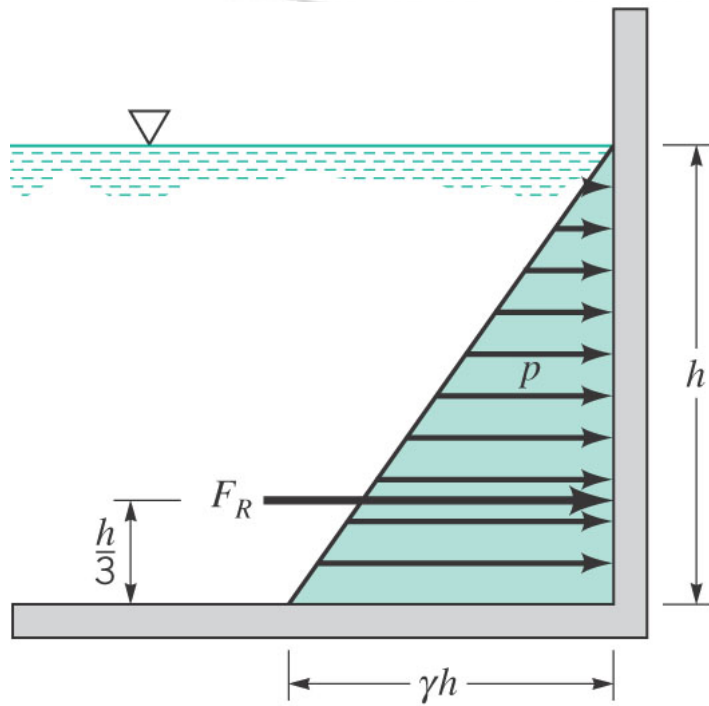

(a)

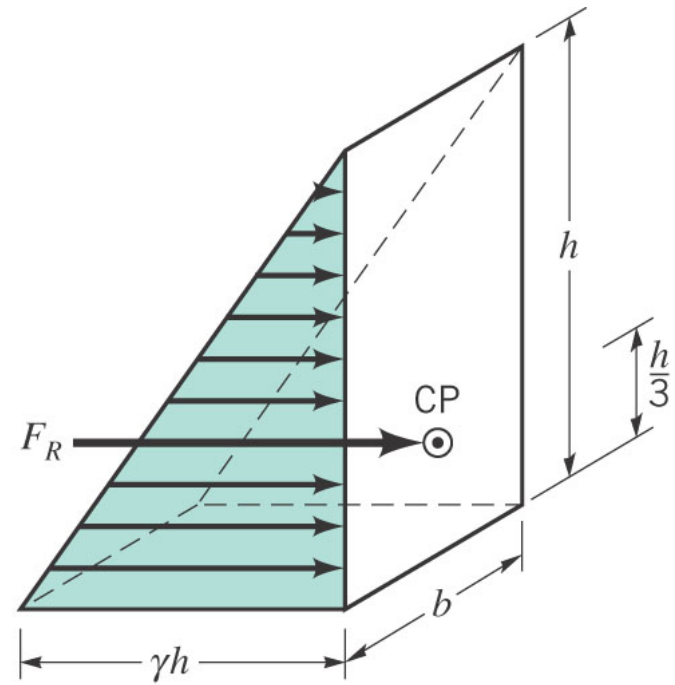

(b)

Curved Surfaces

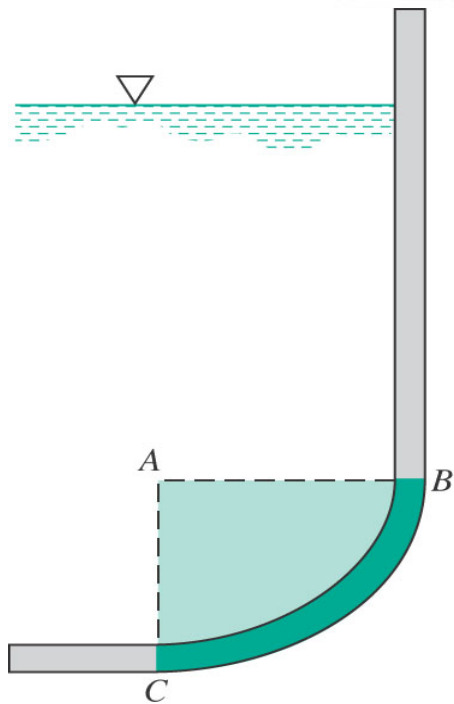

(b)

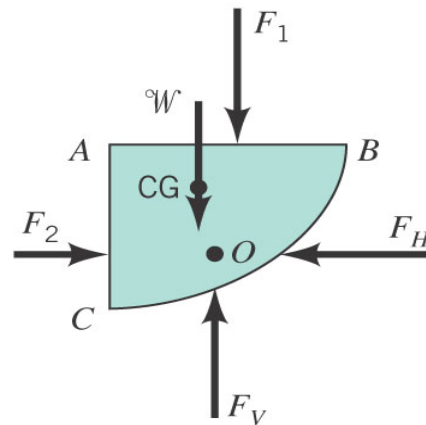

(c)

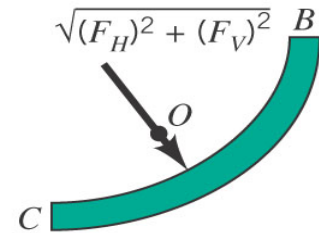

(d)

Archimedes Principle

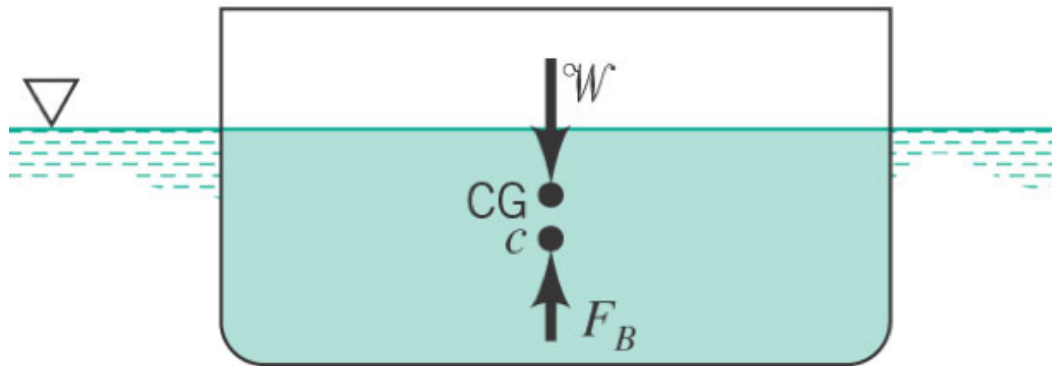

$$F_B = \rho g V_{displaced}$$

Sample Problem

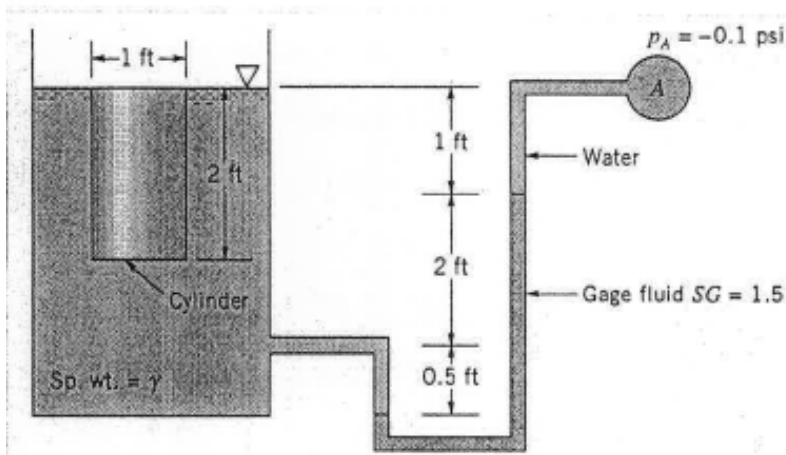

- A cylinder of 1ft diameter and 2 ft length contains a liquid of specific weight γ . A U-tube manometer is connected as shown. In figure the pressure in A is 0.1 psi below atmospheric. What is the weight of the cylinder, whose upper surface is flush with the fluid surface.

Stability

- When in balance the centroid where total weight acts and buoyancy act are aligned
- If not – rotational couple occurs
- Can be stabilizing or destabilizing

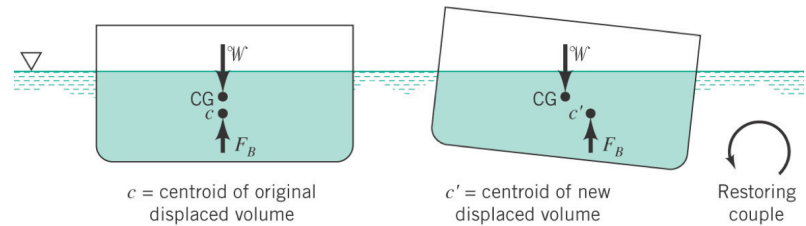

Stable

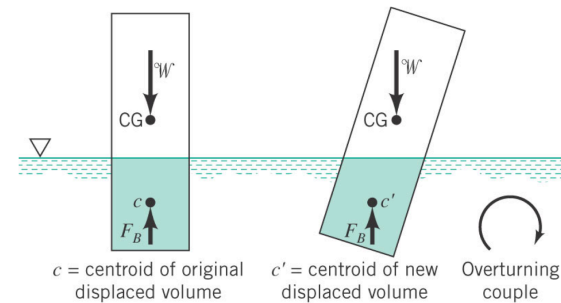

Unstable

Important Equations

- ◆ $dp/dz = -\gamma$ (pressure gradient in a stationary fluid)
- ◆ $F_R = \gamma h_c A$ (hydrostatic force on a plane surface)
- ◆ $y_r = I_{xc} / y_c A + y_c$
 $x_r = I_{xyc} / y_c A + x_c$ (Location of hydrostatic force on a plane)
- ◆ $F_b = \gamma V_{disp}$ (buoyant force)